



AIM HI LED

Floor Stand, Wall & Ceiling Versions

Installation Instructions

Introduction

Congratulations on your purchase of the **AIM HI LED** series light!

The **AIM HI LED** is designed to give the professional health care market superior performance, reliability and value. The lights contain advanced optical and mechanical solutions intended to offer you an optimal working environment for efficient and comfortable procedures. Built in features of the AIM's include intensity control, color correction, shadow reduction, light distribution, spot appearance, maneuverability and focus. The AIM's solid and durable construction ensures trouble-free professional lighting and is supported by a five (5) year service life and warranty.

Intended Use:

The **AIM HI LED** exam light is an easy to use medical lighting fixture that can be utilized in a variety of spaces, including hospitals, doctor offices, and other healthcare environments requiring examination lighting. This fixture shall not be used in healthcare environments that are adjacent to residential dwellings. This fixture is also excluded for use in areas near active HF SURGICAL EQUIPMENT and the RF shielded room of an ME SYSTEM for magnetic resonance imaging, where the intensity of EM DISTURBANCES is high. This product is not intended for use in operating and emergency rooms.

A removable and autoclavable handle (which also serves as bulb-focus control) accepts pre-sterilized covers.

This manual contains guidance on how to install the **AIM HI LED** light(s).

Burton Medical is a leading manufacturer of medical lighting. The product lines encompass lights for procedure and examinations. You are welcome to find out more on our web site at www.burtonmedical.com.

Unpacking and Inspection

Carefully unpack the cartons and match the parts received with the parts list enclosed.

Before Reporting Shortages:

Be sure you have received the correct number of boxes, cartons, etc., as shown on the bill of lading.

Check the entire shipment against the enclosed packing slip.

Items indicated in the column headed "Back Order" are not included in the shipment and will follow later.

Be sure that nothing has been removed from the cartons before they are checked by the individual in charge.

Empty all boxes completely, open all inside containers, and examine all packing material to ensure small articles are not overlooked.

If a Shortage or Damage Occurs:

1. You, the receiver, not Burton Medical, is responsible for filing any claims with the delivering carrier within five (5) days after receipt of the shipment.
2. If damage or shortage occurs in transit, the delivering carrier is required by law to make notation of a shortage or damage. This notation is to be made on the bill of lading.
3. If, in your opinion, there may be concealed damage, an agent from the delivering carrier is obligated to make an inspection after the goods are unpacked.
4. Do not destroy packing material until after the agent has made out his report.
5. All claims must be made to the carrier, not Burton Medical.
6. Written authorization must be obtained from Burton Medical before merchandise can be returned.

Table of Contents

| | |
|--|----|
| 1.0 Tools List | 4 |
| 2.0 Parts List | 4 |
| 2.1 Floor Model | 4 |
| 2.2 Wall Model | 5 |
| 2.3 Single Ceiling Model | 5 |
| 2.4 Double Ceiling Model | 5 |
| 3.0 Safety Instructions | 6 |
| 3.1 Symbols | 6 |
| 3.2 Safety Precautions | 6 |
| 4.0 Floor Stand Model | 7 |
| 4.1 Base Post Assembly | 7 |
| 4.2 Handle Assembly | 12 |
| 4.3 Spring Arm Assembly | 14 |
| 4.3.1 Elbow Cover Removal Instructions | 15 |
| 5.0 Wall Mount Model | 17 |
| 5.1 Mounting Height | 17 |
| 5.2 Ranges of Motion | 17 |
| 5.3 Installation (Wall Support and Anchorage) | 18 |
| 5.4 Connecting Power | 20 |
| 5.4.1 Wall Switch Wiring | 20 |
| 5.4.2 Wall Mount Wiring | 21 |
| 6.0 Ceiling Mount Models | 22 |
| 6.1 Mounting Height | 22 |
| 6.2 Support and Anchorage | 22 |
| 6.3 Cutting the Down Tube | 23 |
| 6.4 Ranges of Motion | 23 |
| 6.5 Ceiling Installation (AIM HI LED Single or Double Ceiling Model) | 24 |
| 6.6 Installing the Junction Box | 25 |
| 6.7 Installing the Ceiling Casting | 25 |
| 6.8 Installing the Down Tube | 25 |
| 6.9 Connecting Power | 27 |
| 6.9.1 Wall Switch Wiring | 28 |
| 6.9.2 Ceiling Mount Wiring | 29 |
| 6.10 Ceiling Bell Housing Assembly | 30 |
| 7.0 Extension/Spring Arm - Wall and Ceiling Assembly | 30 |
| 8.0 Mounting the Light Head to the Spring Arm | 34 |
| 9.0 Cleaning | 35 |
| 9.1 Normal Cleaning | 35 |
| 9.2 Extensive Cleaning | 35 |
| 10.0 Equipment Anchorage Diagrams | 36 |
| 11.0 AIM HI LED Single/Double/Wall Mount Wiring Diagram | 40 |
| 12.0 Warranty Information | 41 |
| 13.0 Equipment Maintenance Log | 42 |
| Burton Medical Information | 44 |

| | |
|--|---|
| The following models are covered in this manual: | 100VAC- 240VAC 50/60Hz |
| AIMLED070 series | |
| ALED070SC | LT, SC, ALED070, BURTON |
| ALED070DC | LT, DBL CEIL, ALED070, 100-240V, BURTON |
| ALED070W | LT, WALL MNT, ALED070, BURTON |
| ALED070FL00 | LIGHT, FL, ALED070, NEMA 5-15P |
| ALED070FL01 | LIGHT, FL, ALED070, CEE 7/7 |
| ALED070FL02 | LIGHT, FL, ALED070, AS/NZS 3112 |
| ALED070FL03 | LIGHT, FL, ALED070, BS1363 |
| AIMLED100 series | |
| ALED100SC | LT, SC, ALED100, BURTON |
| ALED100DC | LT, DBL CEIL, ALED100, 100-240V, BURTON |
| ALED100W | LT, WALL MNT, ALED100, BURTON |
| ALED100FL00 | LIGHT, FL, ALED100, NEMA 5-15P |
| ALED100FL01 | LIGHT, FL, ALED100, CEE 7/7 |
| ALED100FL02 | LIGHT, FL, ALED100, AS/NZS 3112 |
| ALED100FL03 | LIGHT, FL, ALED100, BS1363 |

1.0 Tools List

There will be various tools needed throughout the assembly of the Burton Medical floor, wall & ceiling versions. The tools needed are as follows:

- 2.5mm Allen Key (floor model only, supplied)
- 3mm Allen Key (floor model only, supplied)
- 4mm Allen key (supplied)
- 5mm Allen key (supplied)
- 6mm Allen Key (floor model only, supplied)
- 3/16 Allen key (ceiling mount only, supplied)
- 3/32 Allen key (ceiling mount only, supplied)
- Needle Nose Pliers
- # 2 Phillips Screwdriver
- Medium strength thread locker (Loctite or similar)

NOTE: Retain ALL Allen keys for future maintenance.

3.0 Safety Instructions

NOTE: assembly of this product must be carried out by a trained service technician. At some points of assembly you may require the assistance of an additional person.

- Read these assembly instructions carefully before assembling the **AIM HI LED** light. It will protect you and others from potential injuries that may occur.
- Make sure to follow these instructions when assembling. DO NOT modify or omit any parts on the Burton Medical **AIM HI LED** light before, during, or after assembly.
- If problems are encountered when assembling, contact Burton Medical technical support. The contact information can be found at the end of this manual.
- To avoid an electric shock, make sure the **AIM HI LED** light is not connected to a main power when assembling.
- These assembly instructions only apply to the products listed here and should not be used for any other products.

3.1 Symbols

In these assembly instructions and on the device, important points have been marked with symbols. The symbols have the following meanings:



CAUTION

Non-compliance with caution notes may cause injuries or material damage.



WARNING

Disregarding this instruction can present the risk of serious or fatal injury.



NOTE

Provides usage tips and useful information.



ELECTRIC SHOCK

Electric shock warning symbol. Non-compliance with this symbol may result in injuries due to electric shock.

3.2 Safety Precautions



CAUTION

Failure to properly follow installation and preventive maintenance instructions may result in mechanical and/or electrical failure.



WARNING

Before undertaking any work, ensure that the main power is off and secured from accidentally being switched on again.



NOTE

This light should only be installed by a trained service technician.



NOTE

It is the responsibility of the customer to make sure the supporting wall / ceiling and the anchoring is safe, adequately strong, and in compliance with all applicable building codes. (See Equipment Anchorage Diagrams.)

2.0 Parts List

The Burton Medical lights come in multiple boxes and contain several pieces of hardware, and manuals. Ensure your boxes contain all items as listed below:

2.1 Floor Model

| Part | Quantity |
|----------------------------------|----------|
| Floor Base | 1 |
| Upright Post | 1 |
| Handle with hardware and casters | 1 |
| Spring Arm | 1 |
| Light Head | 1 |

2.2 Wall Model

| Part | Quantity |
|---|----------|
| Extension/Spring Arm (with mounting hardware) | 1 |
| Wall Mount with cover | 1 |
| Light Head | 1 |

2.3 Single Ceiling Model

| Part | Quantity |
|---|----------|
| Extension/Spring Arm (with mounting hardware) | 1 |
| Ceiling Mount with cover | 1 |
| Light Head | 1 |

2.4 Double Ceiling Model

| Part | Quantity |
|---|----------|
| Extension/Spring Arm (with mounting hardware) | 2 |
| Ceiling Mount with cover | 1 |
| Light Head | 2 |

If you are missing any items please contact customer service. See back of manual for contact information.

4.0 Floor Stand Model

4.1 Base Post Assembly Parts (Refer to Figure 1)

| Part # | Qty | Description |
|--------|-----|---|
| A | 1 | Base Cover |
| B | 4 | Base Cover Screws |
| C | 1 | Electrical Switch Nut |
| D | 2 | M8 Attachment Bar Screw and Lock Washer |
| E | 1 | Post Attachment Bar |
| F | 1 | Ground Screw and Washers |
| G | 1 | Post/Upright (not shown below) |
| H | 1 | Push Button Switch |
| I | 1 | Green Indicator Light |

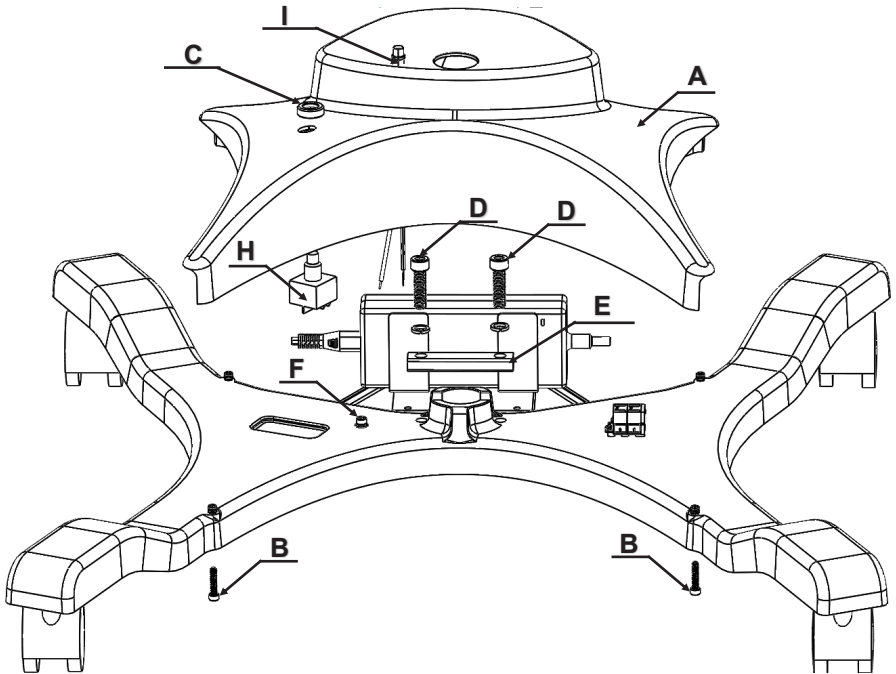

Figure 1.

Assembly Instructions:

1. Using your finger release the fuse holder on the power outlet by pushing downward on the tab and pulling outward. Place the fuse holder aside. See Figure 2.

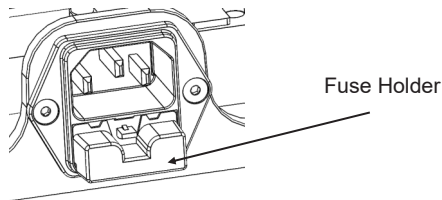

Figure 2.

2. Using a 3mm Allen Key, remove four (4) x M4 screws (B) from underside of base to release the plastic cover. Place screws aside for reassembly. Refer to Figure 1.

- Remove the electrical switch nut (C) by unthreading it from the push button switch (H). Place it aside. Refer to Figure 1.
- Carefully pull the bottom of the plastic cover over the power outlet. Lift the base cover up around 6" (A). Then disconnect red and black wires from green indicator light (I) attached to internal connectors, refer to Figure 3A. To release wire lift corresponding orange tab from each connector, refer to Figure 3B.

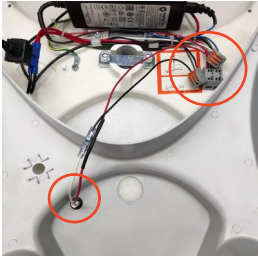

Figure 3A.

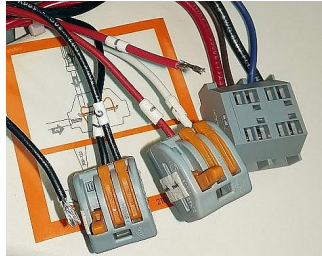

Figure 3B.

- Take the non-flared end of the post base and slide it through the post opening of the base cover. This can be seen in Figure 4.

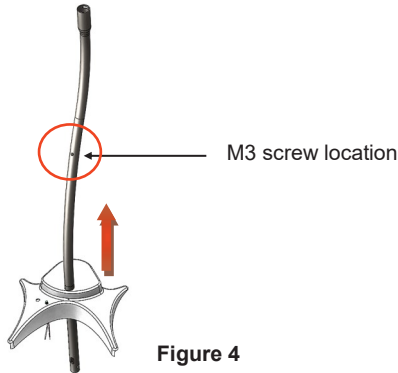

Figure 4

- Using the 2.5mm Allen key, remove the M3 screw on the post. It is located approximately half way up the post. Refer to Figure 4, 5.
- Slide the cover towards the flared end of the post as far as possible. Then re-install the M3 screw into the post. This is to hold the cover up while other work is done. Refer to Figure 5.

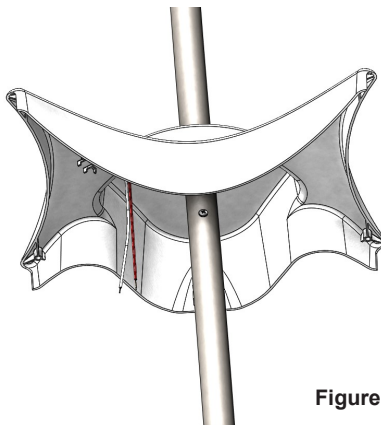

Figure 5: M3 post screw.

8. Using needle nose pliers, pull the connector and approximately one inch of cable through the oval hole at the bottom of the post. Refer to Figure 6.
9. Pull the cable through the opening at the top of the post, until connector is visible. Refer to Figure 7.

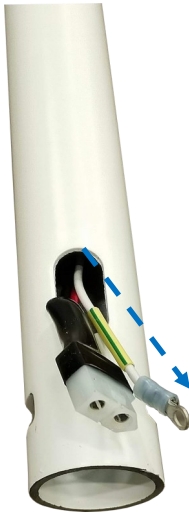

Figure 6: Bottom of the post.



Figure 7: Top of the post.

10. On the base, remove two (2) M8 screws, washers (D), and attachment bar (E) using the 6mm Allen key. Place hardware aside for reassembly. Refer to Figure 8.

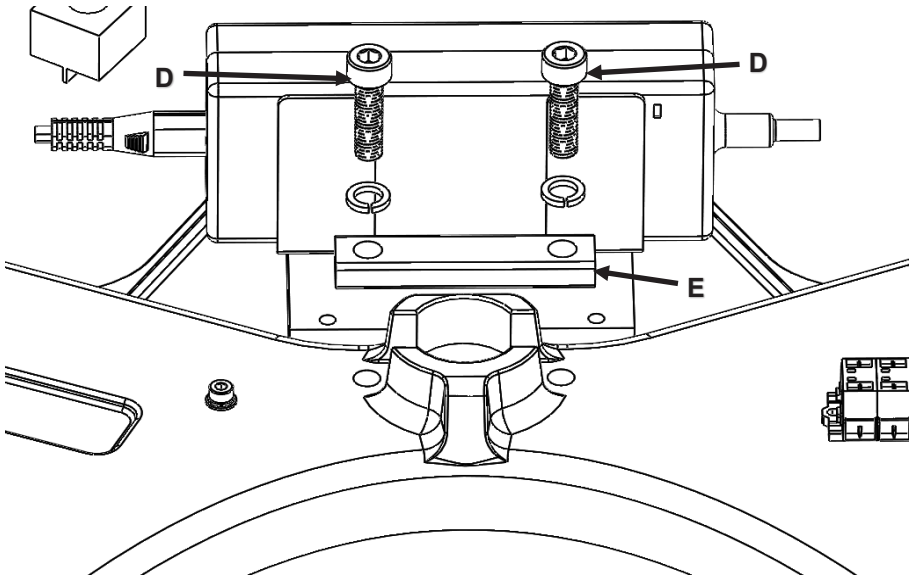

Figure 8: M8 screws and attachment bar.



WARNING: When performing Step 12 to 14, make sure the attachment bar is in proper position in the post, and that it is secure to the base. Failure to do so may cause injury.

11. Position the post so that the arch is located at the back of the base, refer to Figure 9A. Insert the post into the hole in the base. Slide the attachment bar through the square slots in the post. When inserting the post, make sure the wires (A) are facing the front of the base and **NOT** towards the power supply.
12. Align the holes of the attachment bar with the holes on the base (B). Refer to Figure 9B.

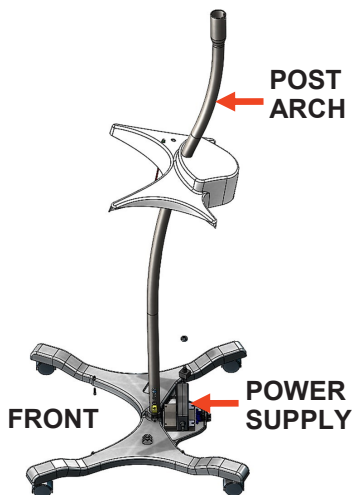

Figure 9A: Post orientation.

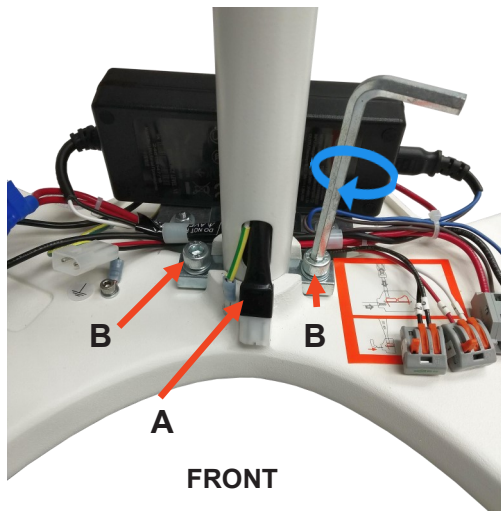
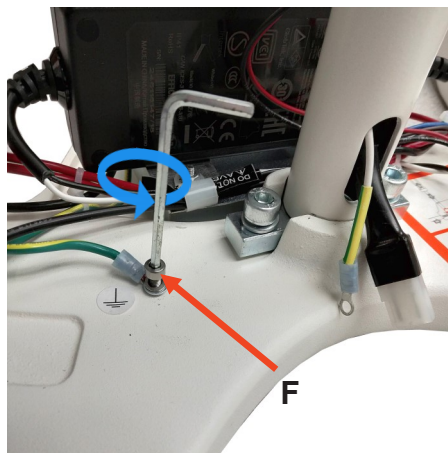

Figure 9B: Post attachment bar.

13. Secure the attachment bar using the two (2) M8 washers and two (2) M8 screws. Tighten the screws using the 6mm Allen key.
14. Ensure that the attachment bar has fully clamped the post and there is no movement of the post.
15. Remove the ground screw and washers (F) using the 3mm Allen key. Refer to Figure 10.



**Figure 10:
Ground screw.**



ELECTRIC SHOCK: Make sure the electrical connection is made properly by following steps below. Failure to do so may cause electric shock. If you have any problems or questions with these steps contact Burton Medical.

- Align the green and yellow ground ring terminal coming out of the post with the green and yellow ground ring already connected to the base. Align them both with the same hole on the base as before, and re-fasten in the same location. See Figure 11A.
- Connect the receptacle coming out from the bottom of the post to the power supply Harness. **CAUTION:** make sure the connectors are fully engaged. See Figure 11B.

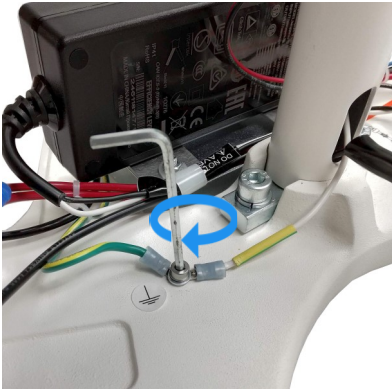

Figure 11A: Ground connections.

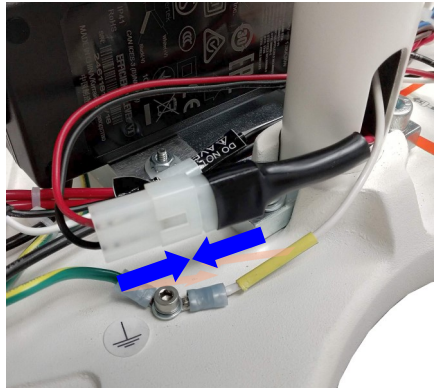

Figure 11B: Power supply connections.

- Remove the M3 screw holding up the base cover and allow the cover to slide down to the base of the floor stand. Replace and secure M3 screw into the post.
- Reconnect wires from Green Indicator switch (I) to its corresponding connectors. Connect RED wire labeled "1" to three port connector labeled "1". Then connect BLACK wire labeled "2" to three port connector labeled "2", refer to Figure 12A. Re-install the pushbutton switch into the underside of the base cover and secure it using the electrical switch nut. Ensure proper orientation of the bottom of the switch into the tabs as shown in Figure 12B.

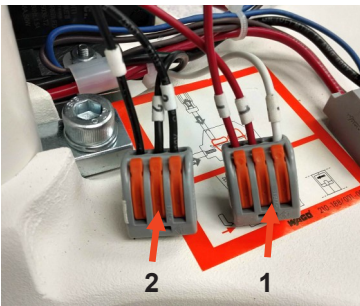

Figure 12A: Green Indicator light connections.

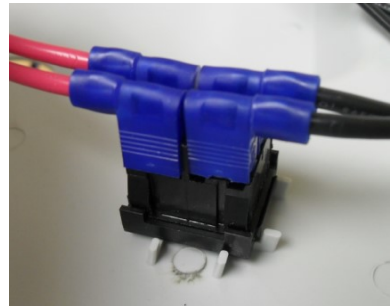

Figure 12B: Proper orientation of foot switch.

- Re-install base cover to the base, by inserting the four (4) M4 screws from below. Ensure the cover is not pinching any wires. Tighten screws using the 3mm Allen key. **Do not overtighten!**
- Reinstall fuse holder removed in step 1, ensuring fuse holder clicks into place and is secure.

4.2 Handle Assembly

| Part # | Qty | Description |
|--------|-----|----------------|
| G | 1 | Post / Upright |
| J | 1 | Handle |

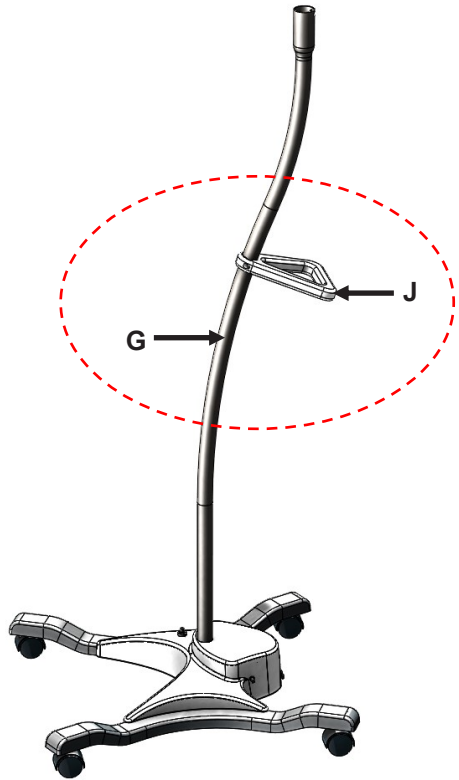

Figure 13: Post and handle assembly.

Assembly Instructions:

1. Remove the screws in the handle using a Phillips screwdriver to separate it into two pieces.
2. On the smaller portion of the handle there is larger center hole. This hole is used for positioning the handle to the post. Ensure the head of the positioning screw (which is located half way up the post) is inserted into this hole. Refer to Figure 14A & B.

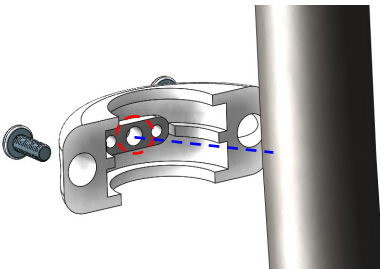

Figure: 14A

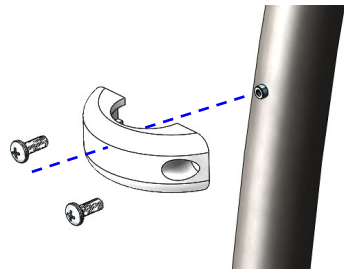

Figure: 14B

3. With small piece positioned over the posts setscrew, feed two Phillips screws on each side, refer to Figure 15A. Then attach large handle to the post on the opposite side, refer to Figure 15B. Using Phillips screwdriver engage 3-4 threads of the first screw then repeat the process on the opposite screw. Secure the handle to the post by hand tightening both screws.

WARNING: Alternate tightening each screw to prevent handle from binding.

WARNING: Do not overtighten, leave small gap of equal size between small piece and large piece of the handle, refer to figure 16B.



Figure: 15A

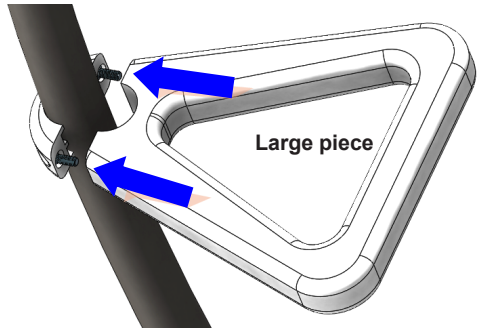

Figure: 15B

4. Properly installed handle, refer to Figure 16A & B.

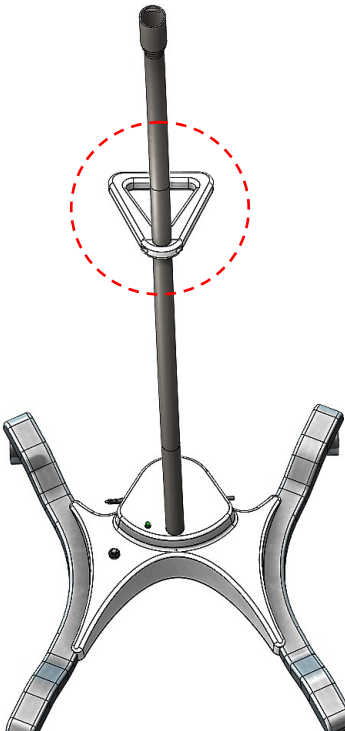

Figure: 16A

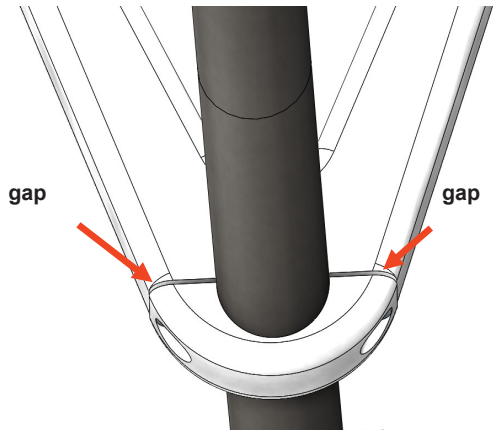

Figure: 16B

4.3 Spring Arm Assembly

| Part # | Qty | Description |
|--------|-----|-----------------------|
| G | 1 | Post/Upright Assembly |
| K | 1 | Spring Arm Assembly |
| L | 1 | Elbow Cover |

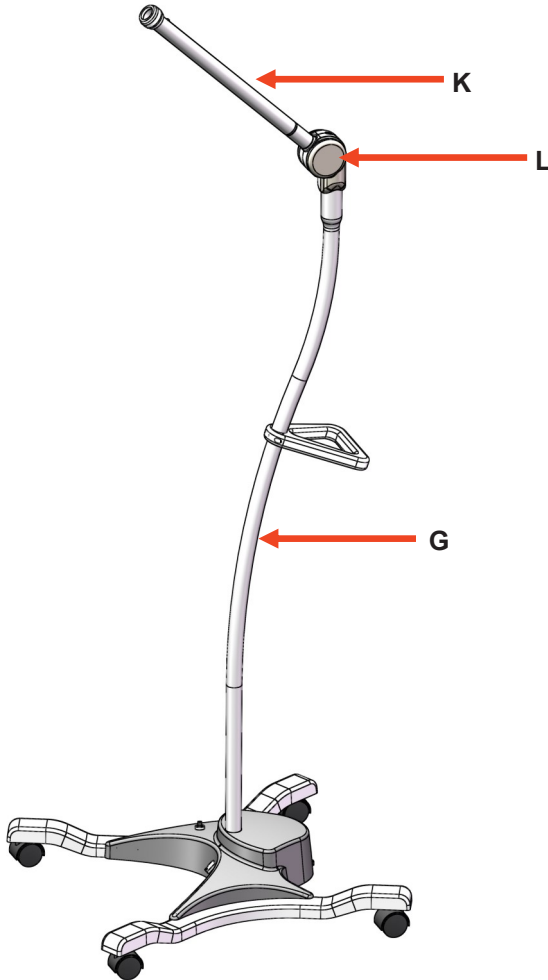

Figure 17: Spring arm assembly.

Assembly Instructions:

1. Remove the spring arm elbow covers (L). Refer to Figure 18.

4.3.1 Elbow Cover (L) Removal Instructions:



Step 1: Covers Installed.



Step 2: Insert slot driver into the parting line as shown.



Step 3: Turn driver 90° to separate the covers.



Step 4: Pry the LH cover up.

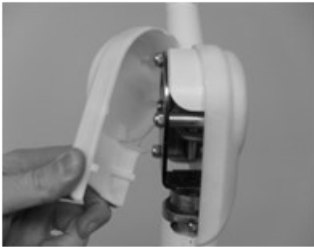

Step 5: Pry the LH cover forward.



Step 6: Pry the RH cover up.



Step 7: Pry the RH cover forward.

Figure 18: Elbow cover removal instructions.

2. With covers removed, use a 3mm Allen key to remove the rotational stop screw (B) and lock washer (C) from the back of spring arm post. Take care to ensure the lock washer (C) and shim washer (A) do not fall off during this step. See **Figure 19**.
3. Connect the spring arm electrical connector to the mounting post electrical connector by pushing them together.
4. Slide the spring arm into the mounting post. Ensure the washer (A) is present and did not fall off the spring arm shaft.
5. Using 3mm Allen key, fasten the rotational stop screw with lock washer into the back of the spring arm post. Refer to **Figure 20**.

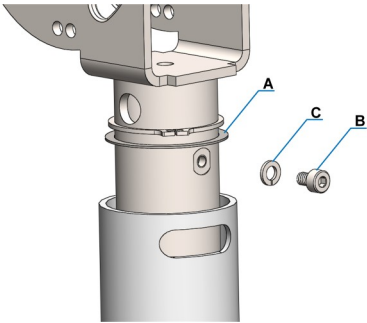

Figure 19: Remove stop screw.

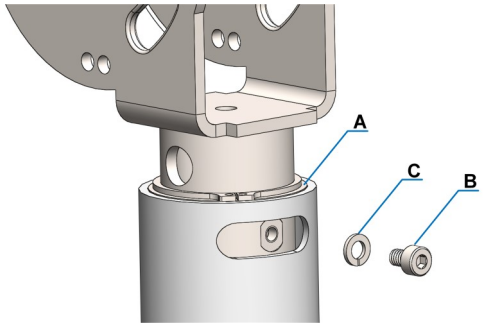
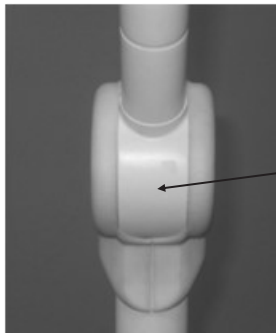

Figure 20: Install stop screw.



WARNING: Always make sure the rotational stop screw is properly fastened to avoid a safety hazard.

6. Gently snap right hand cover onto spring arm in reverse order of removal instructions described above. When performing this step, ensure that the sliding cover (already on the spring arm) mates with a groove on the inside of the spring arm cover. Refer to Figure 21.
7. Gently snap left hand cover onto spring arm in reverse order of removal instructions described above. When performing this step, ensure that the sliding cover (already on the spring arm) mates with a groove on the inside of the spring arm cover. Also ensure that both covers mate properly to each other as they are snapped together. Refer to Figure 22.



Sliding
Cover

Figure 21 & 22: Left and right hand cover assembly.

For instruction on how to Mount the Light Head to the Spring Arm follow steps in section “**9.0 Mounting the Light Head to the Spring Arm**”

5.0 Wall Mount Model

5.1 Mounting Height

The proper height of the light should be set by the end user. This depends on the height of the examination tables, types of procedures and the user's preferences. (See Figure 23)

The following table shows the range of the light with the different mounting heights.

| Mounting Height A | Pivot Point B | Lower Limit C | Higher Limit D |
|-------------------|-----------------|-----------------|------------------|
| 8.0 ft (2440 mm) | 67 in (1702 mm) | 43 in (1092 mm) | 84 in (2134 mm) |
| 9.0 ft (2745 mm) | 79 in (2007 mm) | 55 in (1397 mm) | 96 in (2438 mm) |
| 10.0 ft (3050 mm) | 91 in (2311 mm) | 67 in (1702 mm) | 108 in (2743 mm) |

5.2 Ranges of Motion

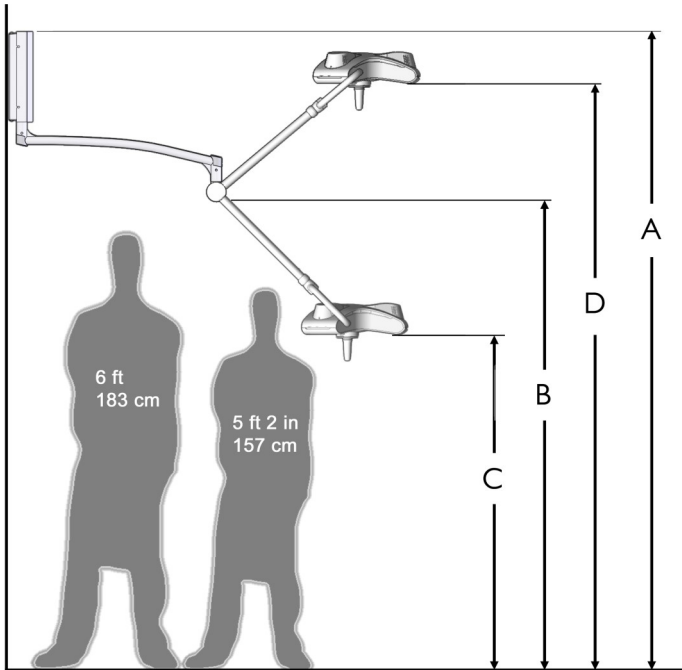

Figure 23: Vertical range of motion.

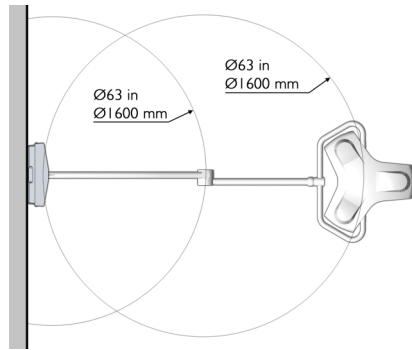

Figure 24: Horizontal range of motion.

5.3 Installation

Wall Support Structure

The engineer of record for the building shall provide a support structure designed to support weights and forces shown on the Equipment Anchorage Diagrams in this manual.

Assembly Preparations

Tools and Accessories Required:

- Drill
- Level
- 9/16" (14,3 mm) open-end key (or adjustable key)
- Wire cutter/stripper
- Allen key (3/32 in / 2,4 mm)
- Screwdriver, small flat-blade
- Screwdriver, small Phillips
- Wire nuts and wiring for supply connections

Materials Required:

- Mounting plate. (See page 19)
- Washers and spacers. (For mounting flush with wall)
- Special anchors for concrete or brick walls.
- Switch box – For wall switch panel.
- Electrical wire—To light.
- Conduit for electrical lines to wall mount / switch.
- Wall switch.

Support and Anchorage



To prevent sway and provide proper support of the light, the wall mount must be attached to a structurally-sound wall or similar structure.

Most walls will require adequate reinforcing to hold the light. The installing contractor is responsible for providing this reinforcement to suit the individual requirements for each installation.

A typical reinforcement consists of a ¼" steel plate. Make certain the mounting plate is vertical, or the arm may "drift".

Equipment anchorage diagrams are supplied with these instructions to help with the installation. The diagrams were prepared by a California-licensed Structural Engineer. If the lights are installed accordingly, the system will meet requirements of the State Seismic Codes.

Installing the Wall Mount

| | | |
|---|----------------|---|
|  | WARNING | Before cutting the wall, check with building maintenance so that you do not cut through existing electrical, plumbing or gas lines. |
|  | NOTE | It is the responsibility of the contractor and engineer of record to design and build a suitable structure for mounting the light |

- Figure 25 shows an example of a mounting plate (not included), of minimum thickness 3/16", which can be used to mount the wall mount. The attachment method (screws), number of screws, and location of the screws will vary depending on the type and structure of the wall, therefore it is not shown.

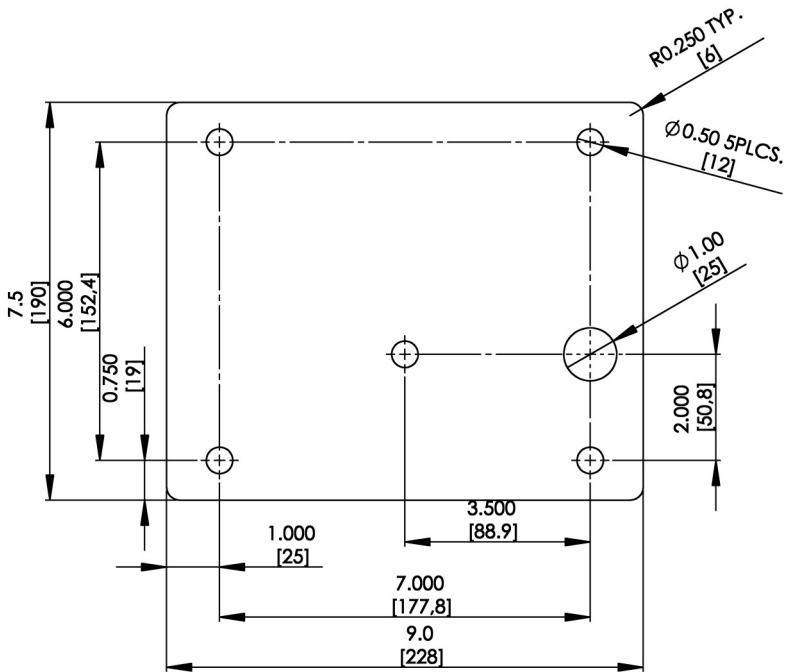



Figure 25: Contractor supplied mounting plate (dimensions are inches [mm]).

- Install the mounting plate (not included) to the bearing structure of the wall.
- Feed the wires coming through the central hole in the mounting plate into the wall mount assembly.
- Install the wall enclosure to the mounting plate. Use four (4) 3/8" (10 mm) bolts, flat washers, split lock washers, and nuts.

5.4 Connecting Power

| | | |
|--|-------------|--|
|  | NOTE | Wires and cabling to be routed and connected by certified electrical contractor. |
|--|-------------|--|

5.4.1 Wall Switch Example



| | | |
|--|-------------|---|
|  | NOTE | Wall switch is not included with the Burton product, however a switch is mandatory for all W, SC, DC installations and it must be furnished and installed by End User. Install wall switch per national and local electrical codes. |
|--|-------------|---|

5.4.2 Wall Mount Wiring

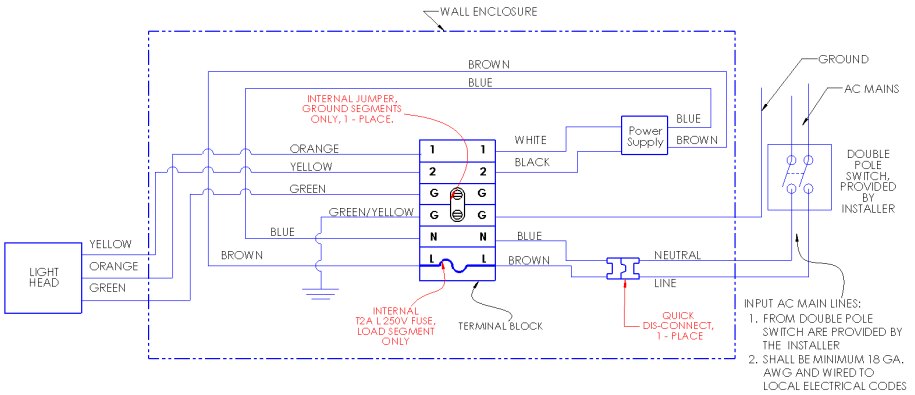

Figure 26A: Wall mount wiring diagram.

1. Route conduit and electrical lines from wall switch to wall mount. Connect green ground wire to either of green terminal blocks labeled with ground symbol. Connect Line and Neutral wire to orange quick disconnect connector, refer to Figure 26A & B. **NOTE:** the terminal block is marked with numbers and electrical symbols to designate correct wiring.

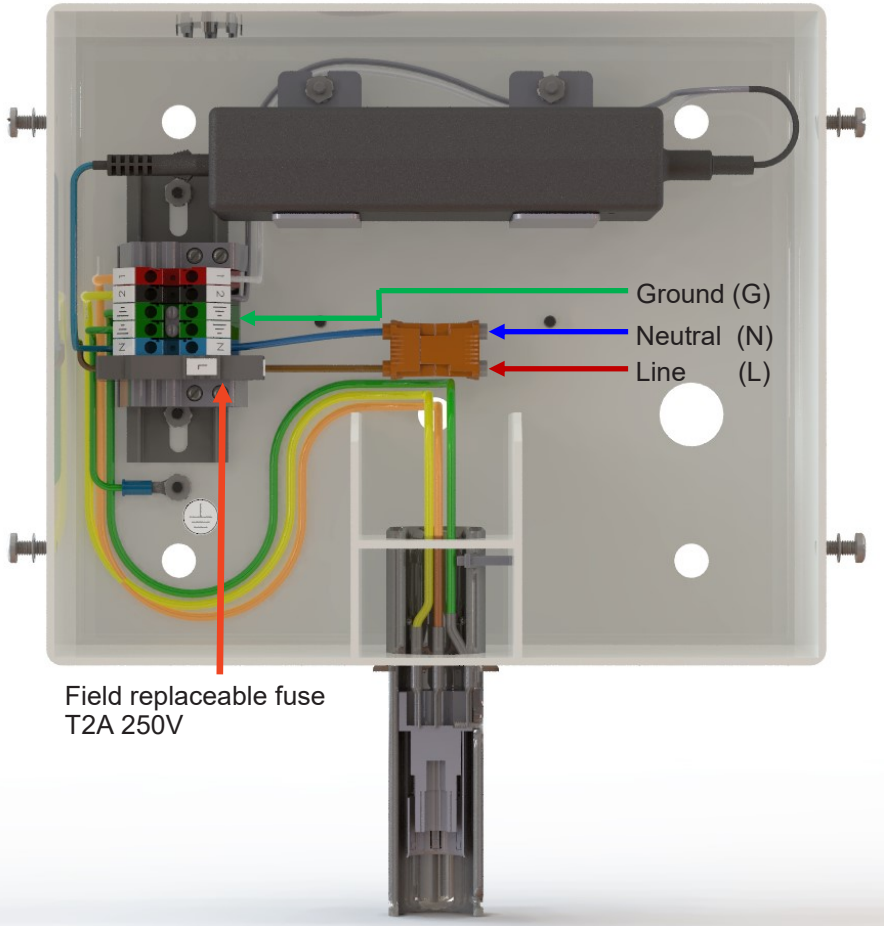

Figure 26B: Wall mount wiring diagram.

2. Install the cover on the wall mount and secure it by tightening the 4 screws with serrated lock washers on the sides. **NOTE:** Serrated washer must be in place to ensure proper grounding of the cover.

For instruction on how to install Extension/Spring Arm to wall mount follow steps in section **“8.0 Extension/Spring Arm - Wall and Ceiling Assembly”**

For instruction on how to Mounting the Light Head to the Spring Arm follow steps in section **“9.0 Mounting the Light Head to the Spring Arm ”**

6.0 Ceiling Mount Models

Assembly Preparations

Tools and Accessories Required:

- Drill
- Hacksaw
- Level
- 9/16" (14,3 mm) open-end key (or adjustable key)
- Wire cutter/stripper
- Allen key (3/32 in / 2,4 mm)
- Screwdriver, small flat-blade
- Wire nuts and wiring for supply connections

6.1 Mounting Height

The proper height of the light should be set by the end user. This depends on the ceiling height, the height of the examination tables, types of procedures and the user's preferences (See Figure 1 on page 25.) Due to the large vertical range of the light head (41 in / 1040 mm), the standard 20 inch down tube will fit most normal ceiling heights.

The following table gives some recommendations and shows the range of the light with different length down tubes.

| Ceiling Height | Down Tube | Pivot Point ¹ | Lower Limit Light Head | Higher Limit Light Head |
|--------------------|-----------------------|--------------------------|------------------------|-------------------------|
| 8.0 ft. (2439 mm) | Standard 20" | 66 in. (1676 mm) | 42 in. (1067 mm) | 83 in. (2108 mm) |
| 9.0 ft. (2743 mm) | Standard 20" | 78 in. (1981 mm) | 54 in. (1372 mm) | 95 in. (2413 mm) |
| 10.0 ft. (3048 mm) | Standard 20" | 90 in. (2286 mm) | 66 in. (1676 mm) | 107 in. (2718 mm) |
| | Long 42" ² | 66 in. (1676 mm) | 42 in. (1067 mm) | 83 in. (2108 mm) |
| 11.0 ft. (3353 mm) | Long 42" ² | 78 in. (1981 mm) | 54 in. (1372 mm) | 95 in. (2413 mm) |
| 12.0 ft. (3658 mm) | Long 42" ² | 90 in. (2286 mm) | 66 in. (1676 mm) | 107 in. (2718 mm) |

¹Distance from the floor to the pivot point of the spring arm.

²Contact Burton Medical to obtain a 42" or 52" down tube (special order).

6.2 Support and Anchorage

To prevent sway and provide proper support of the light, the ceiling mount must be attached to a structurally-sound ceiling. Most ceilings will require adequate reinforcing to hold the light.

The installing contractor is responsible for providing this reinforcement to suit the individual requirements of each installation. A typical reinforcement consists of a ¼" steel plate, the bottom surface of which is flush with the inside surface of the finished ceiling (e.g., acoustical tile) and connected firmly to the structural ceiling. Sway braces (e.g., made of angle iron) are recommended when there is more than 12" between the structural and finished ceilings. Make certain the installed plate is level or the arm(s) may "drift".

Equipment anchorage diagrams are supplied with these instructions to help with the installation. The diagrams were prepared by a California-licensed Structural Engineer. If the lights are installed accordingly, the systems will meet requirements of the California State Seismic Codes.

6.3 Cutting the Down Tube

If shortening the down tube is required, the following procedure applies:
 Cut the down tube from the top to the appropriate length (the top of the down tube has 2 holes, the bottom has 6 holes). **Do not cut down tube to less than 12"**.
 Drill new holes on the top of the down tube according to the drawing below.

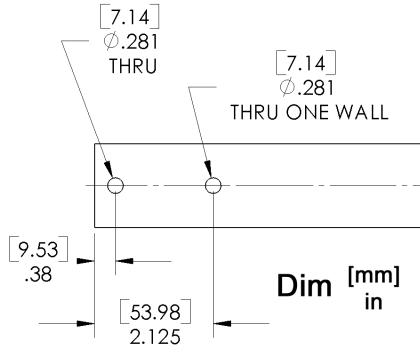

Figure 27: Down Tube drawing.

6.4 Range of Motion

Range of Motion for Single Ceiling

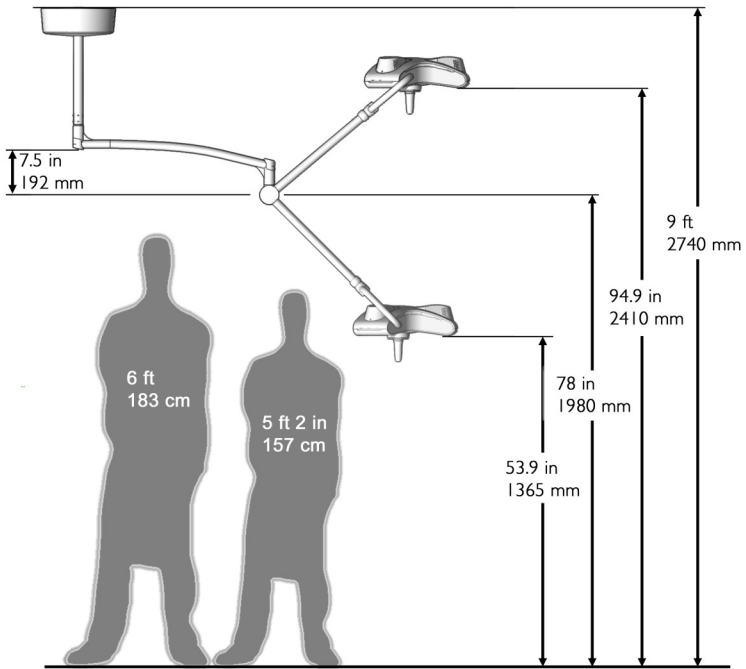

Figure 28: Vertical range of motion. Shown for 9 ft. ceiling height.

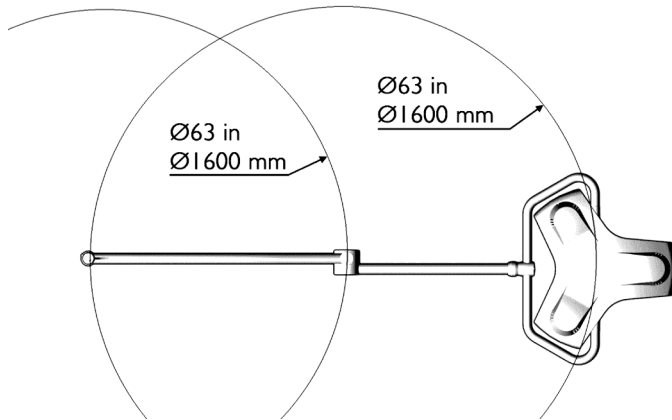

Figure 29: Horizontal range of motion (unlimited rotation in both axis).

Range of Motion for Double Ceiling

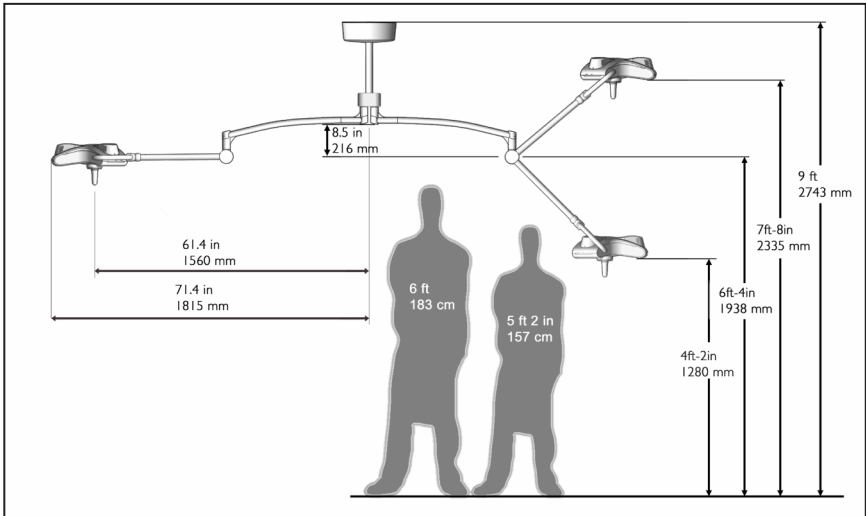

Figure 30: Range of motion shown for 9 ft ceiling and 20 inch down tube.

6.5 Ceiling Installation (AIM HI LED Single or Double Ceiling Model)

Ceiling Support Structure

NOTE: The engineer of record for the building shall provide a support structure designed to support weights and forces shown on the Equipment Anchorage Diagrams.

6.6 Installing the Junction Box

Installing the Junction Box

The junction box should normally be placed on top of the support structure. Make sure the screw holes on the junction box plate correspond to the holes in the ceiling casting. When the ceiling plate is installed, the bolts will also hold the junction box. If there isn't space for the junction box on top of the support structure, another suitable location in the ceiling can be used. It is also possible to use a different junction box if that is more convenient.

6.7 Installing the Ceiling Casting

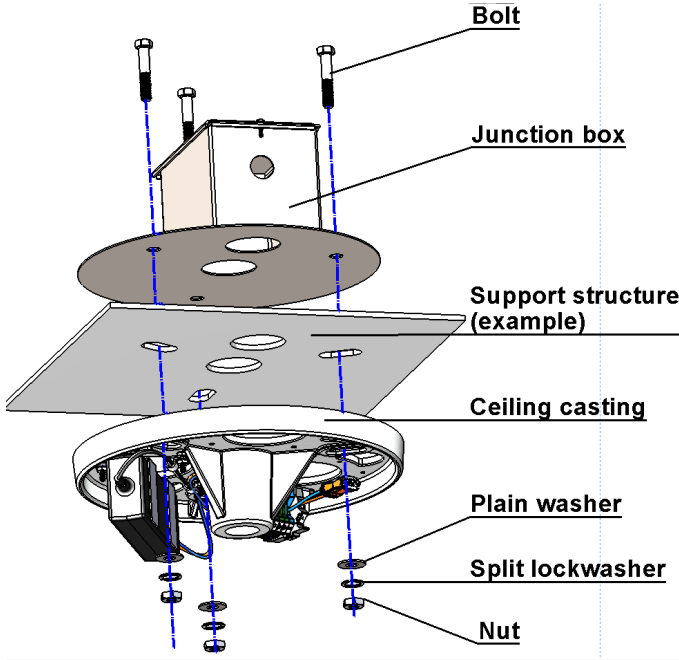

Figure 31: Ceiling mount assembly

NOTE: Illustration is for single ceiling version, so only one power supply is shown.

Mount the ceiling casting to the support structure. Make sure the hole in the ceiling casting above the terminal block aligns with the hole in the junction box. Use three (3) 3/8" bolts, plain washers, split lock washers, and nuts in a triangular pattern. See Equipment Anchorage Diagrams for details and refer to your local building codes.

6.8 Installing the Down Tube

| | | |
|--|-------------|---|
| | NOTE | The down tube is pre-cut and pre-drilled at the factory and will suit most exam rooms with a ceiling height of 8-10 ft. Refer to section 6.1 Mounting Height™ for further advice. |
| | NOTE | Be certain to slide the bell housing and locking ring on the down tube before inserting the down tube into the ceiling casting. |

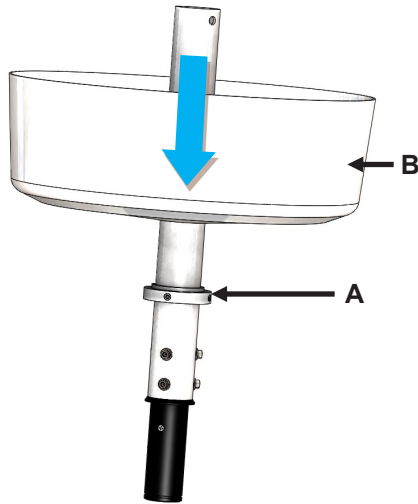

Figure 32: Ceiling down tube assembly.

Slip the locking ring (A) and the bell housing (B) onto the down tube.

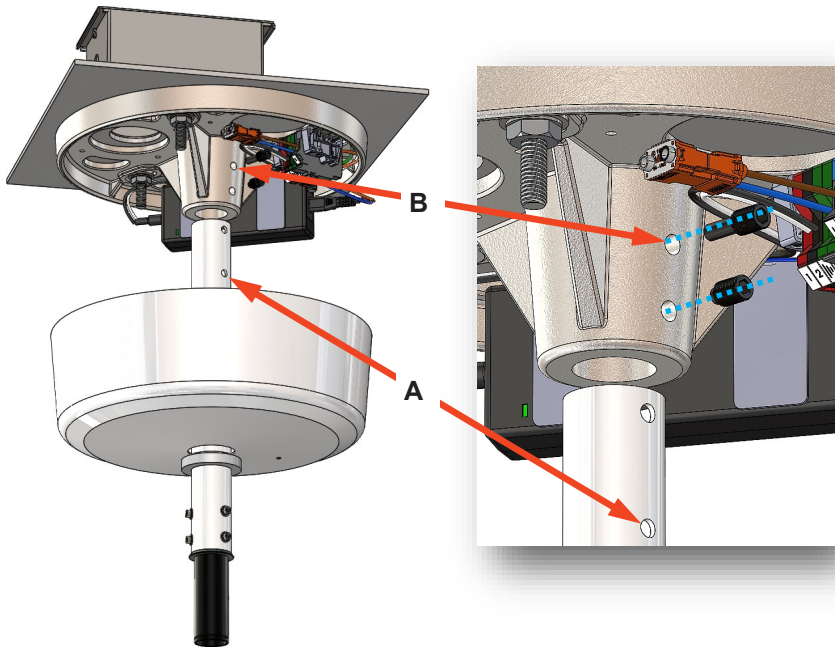

Figure 33A: Ceiling casting to down tube assembly.

NOTE: This illustration above is for single ceiling version, and only one power supply is shown.

Assemble the down tube by sliding it up center hole in the ceiling casting. Position the tube so that the lower hole (A) in the down tube is aligned with upper hole (B) of the ceiling casting. Use thread locker (Loctite or similar) on screws to prevent them from becoming loose. First fasten the upper set screw, which is a dog point screw. Make sure it fully engages the hole of the down tube. Next fasten lower set screw, refer to Figure 33A.

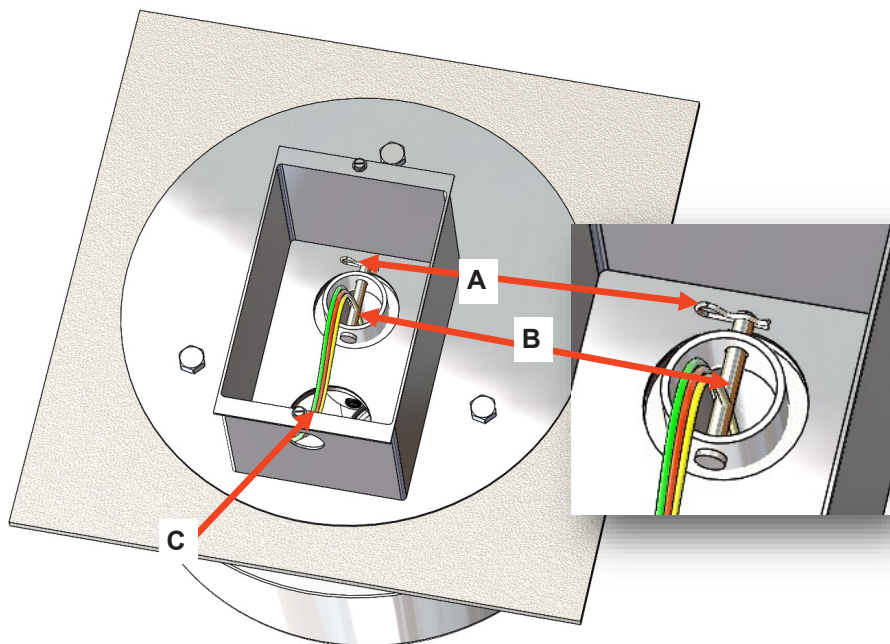

Figure 33B: Ceiling casting to down tube assembly.



WARNING: Clevis pin **MUST** be installed and secured with cotter pin. Disregarding this instruction can present the risk of serious or fatal injury.

Approximately 1 inch of the down tube should project above the ceiling plate and a hole in the down tube will be accessible. Put the clevis pin (B) into the hole. Secure the clevis pin with the cotter pin (A), refer to Figure 33B.

Feed the wires coming up out of the down tube back down through the hole in the ceiling casting (C). The wires from the wall switch should also go through this hole, refer to Figure 33B.

6.9 Connecting Power



ELECTRIC SHOCK: Disconnect all power and remove all fuses prior to assembly.

6.9.1 Wall Switch Wiring



NOTE

Wires and cabling to be routed and connected by certified electrical contractor.



NOTE

Wall switch is not included with the Burton product, however a switch is mandatory for all W, SC, DC installations and it must be furnished and installed by End User. Install wall switch per national and local electrical codes.



Figure 34: Wall Switch Example

Route conduit and electrical lines from wall switch to ceiling mount through junction box. Connect green ground wire to either of green terminal blocks labeled with ground symbol. Connect Line and Neutral wire to orange quick disconnect connector, refer to Figure 26A & B. **NOTE:** The terminal block is marked with numbers and electrical symbols to designate correct wiring.

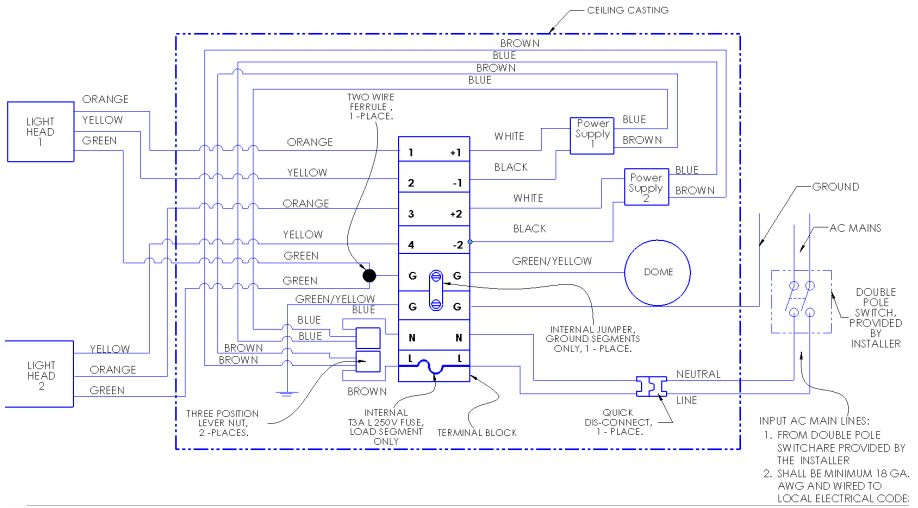

Figure 36A: Double ceiling wiring diagram.

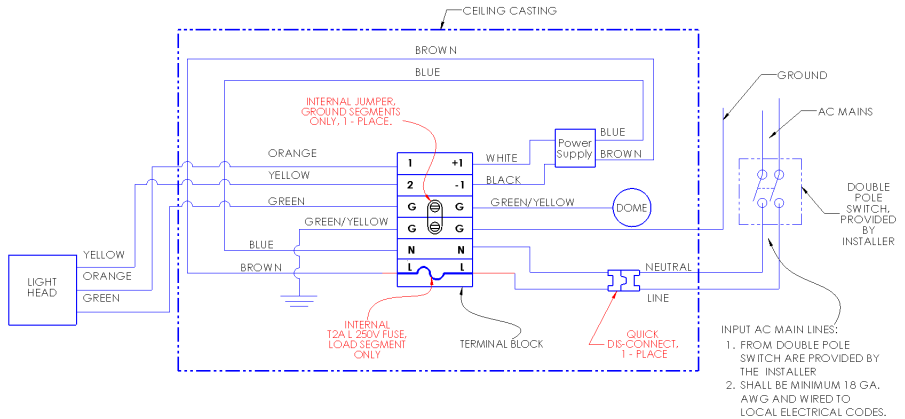

Figure 36B: Single ceiling wiring diagram.

6.9.2 Ceiling Mount Wiring

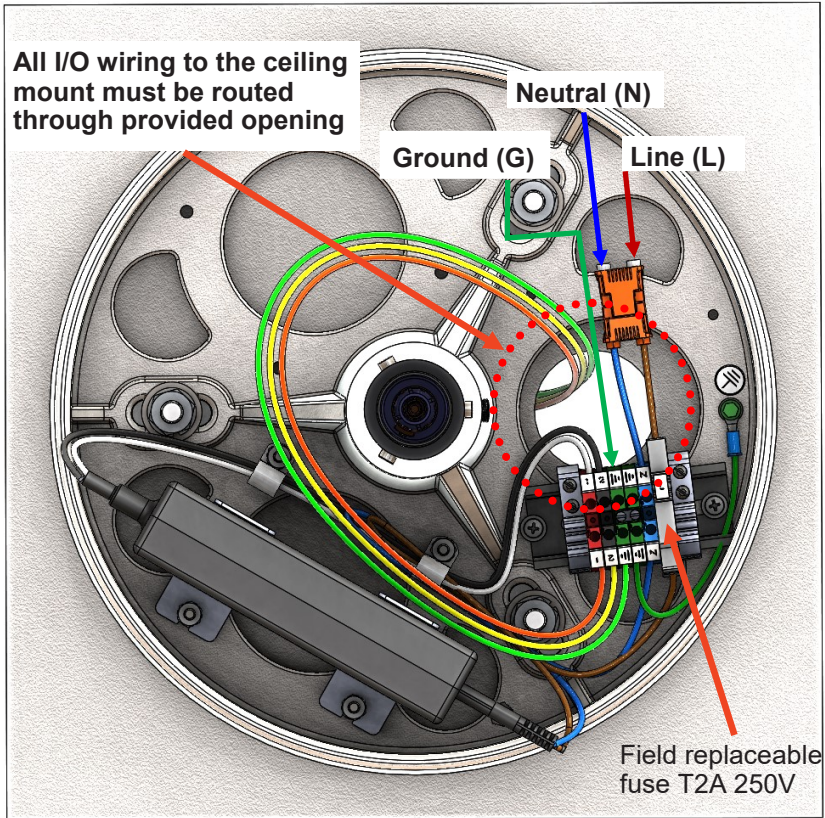

Figure 36C: Single or double ceiling wiring diagram (single ceiling shown)

Output Power:

Connect output lead wires, coming from the down tube, Orange (labeled 1), Yellow (labeled 2) and Green/Yellow as follows:

- Green/Yellow to **green** terminal block (for double ceiling version connect second Green/Yellow to any available **green** terminal blocks)
- Orange to terminal block labeled **1** (and **3** for double ceiling version) (+)
- Yellow to terminal block labeled **2** (and **4** for double ceiling version) (-)

Input Power (from wall switch furnished by End User):

- Connect one (**BRN**) wire to terminal block labeled "L" line.
- Connect one (**BLU**) wire to terminal block labeled "N" neutral.
- Connect (**YEL/GRN**) ground wire to either of green terminal blocks.

NOTE: Mains wire color designation can vary and be subject to National or Local Electrical codes.

6.10 Ceiling Bell Housing Assembly

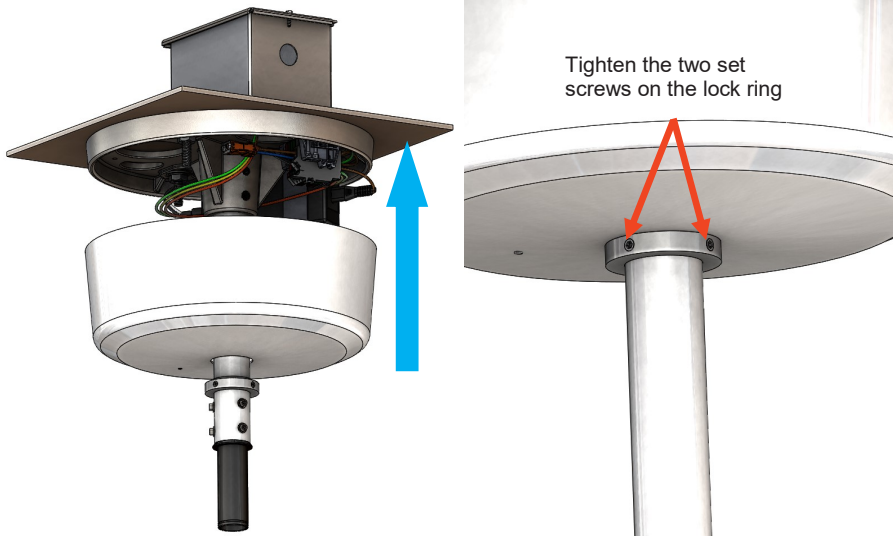

Figure 37: Ceiling bell housing assembly.

Connect the ground wire on the bell housing to the green terminal block on the casting. Push the bell housing and the lock ring up until it covers the ceiling plate. Tighten the two set screws on the lock ring using a 3/32 in. Allen key.

7.0 Extension/Spring Arm - Wall and Ceiling Assembly

Place Extension/Spring Arm onto a flat surface before continuing with following steps. Locate the plastic bag, secured to the arm, containing hardware kit.

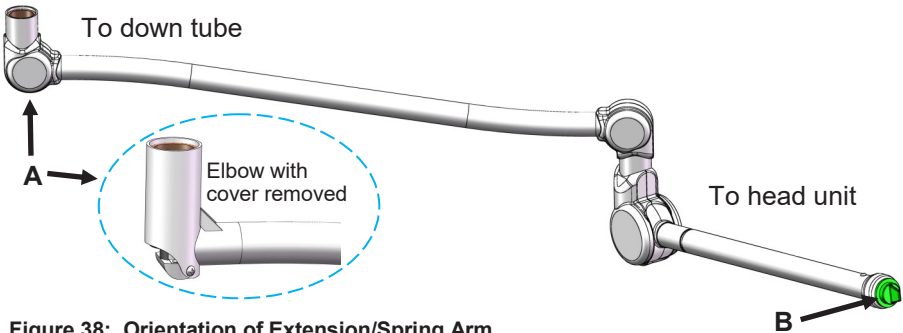
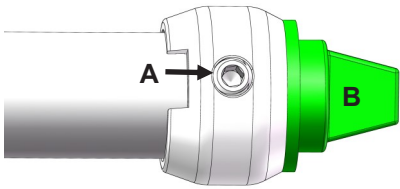

Figure 38: Orientation of Extension/Spring Arm.

Assembly Instructions:

1. Remove the elbow cover from one end (A) of the Extension/Spring Arm. For detailed instructions on how to remove cover, refer to table of contents for “Elbow cover removal instructions”. Set the covers aside.
2. Remove green plug (B) from end of the spring arm as follows:



Step 1
Locate spring arm collar, set screw (A) and plug (B) at end of spring arm

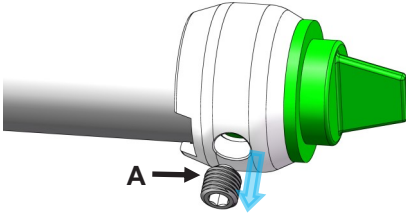

Step 2
Remove the set screw (A) from collar.

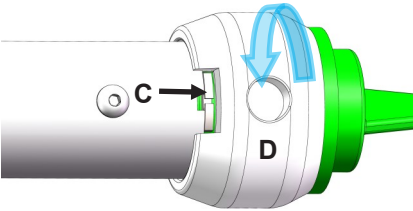

Step 3
Rotate collar (D) 180° until the collar notch exposes the locking key (C) on the spring arm.

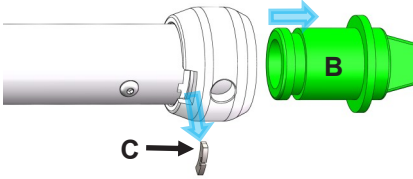

Step 4
With needle nose pliers, remove the locking key (C) and a green plug (B) from spring arm. Discard green plug.

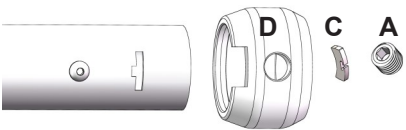

Step 5
Remove collar (D), and set it aside together with set screw (A) and locking key (C).

CAUTION: Do not lose these parts.

Figure 39: Extension/Spring Arm green plug removal.

3. Remove the electrical connector (slip ring) by unscrewing the two screws and placing them aside. Slide out the electrical connector from the tube and allow it to hang off to the side. Refer to Figures 40 and 41.

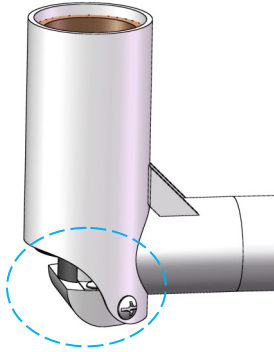

Figure 40: Electrical Connector.

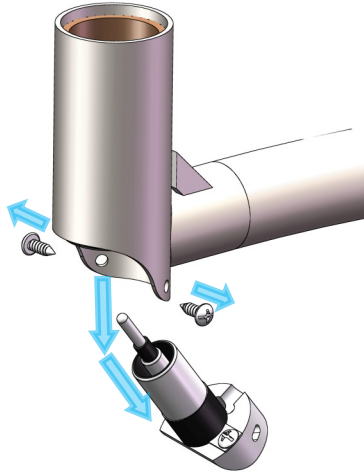

Figure 41: Electrical connector (slip ring) removed.

4. Slide the Extension/Spring Arm assembly up and onto the ceiling mount down tube and hold it in place. Refer to Figures 42 and 43.

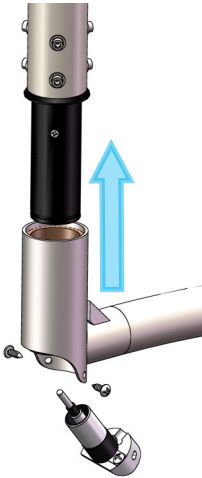

Figure 42.

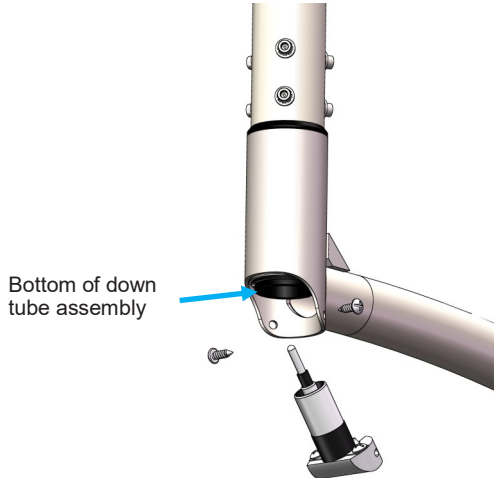

Figure 43.

5. Remove the 2 x Retaining Rings, 1 x Safety Washer and 1 x Retaining Ring Washer from the arm's hardware kit. Refer to Figure 44 (D, E and F).

| Part # | Qty | Description |
|--------|-----|-------------------------------|
| A | 1 | Extension/Spring Arm Assembly |
| B | 1 | Wall/Ceiling mount down tube |
| C | 2 | Slip Ring Screws |
| D | 1 | Safety Washer |
| E | 1 | Retaining Ring Washer |
| F | 2 | Retaining Rings |

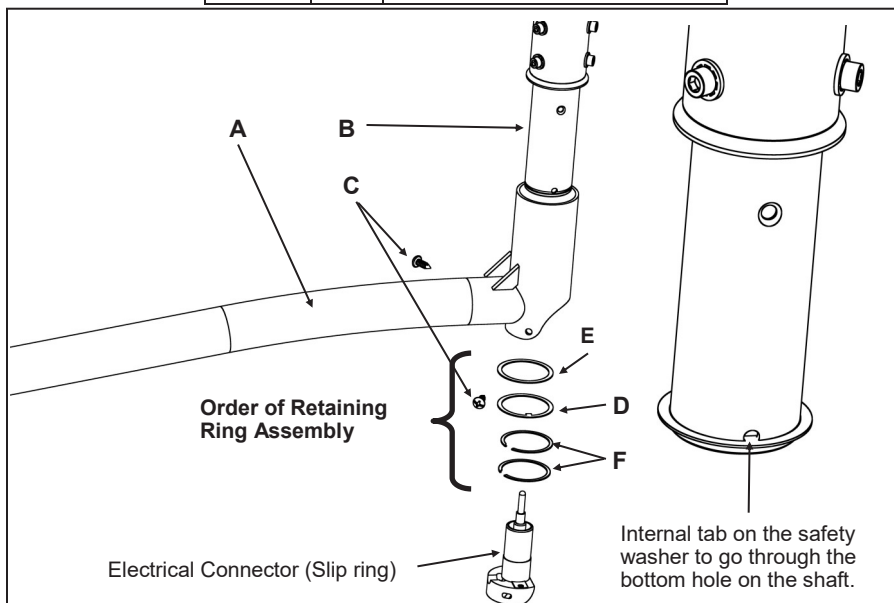



Figure 44: Extension/Spring Arm assembly.

6. Install the retaining ring washer, then install the safety washer with the notch facing into the hole, and finally snap the two retaining rings into the groove. Refer to Figure 44.

| | |
|--|--|
| | WARNING: It is critical that the retaining rings and washers be installed in given order per Step 6 and Figure 44. Disregarding this instruction can present the risk of serious or fatal injury. |
| | WARNING: It is critical that the retaining rings are fully seated inside the down tube shaft's groove. Disregarding this instruction can present the risk of serious or fatal injury. |
| | WARNING: It is critical that the safety washer tooth is properly inserted into the hole of the down tube shaft to avoid a potential safety hazard. The safety washer acts as a secondary safety support in the case that both retaining rings fail. |

7. The extension/spring arm is now correctly mounted to the wall/ceiling.
8. Reposition the electrical connector (slip ring) up into the extension/spring arm, and secure it into place using the two screws which were set aside.
9. Reinstall the covers by reversing the instructions followed for cover removal. Gently snap the 2 pieces together, and check the parting line to ensure proper fit with no gaps.

8.0 Mounting the Light Head to the Spring Arm

| | |
|---|---|
|  | WARNING: The spring arm is under a high spring load. If the spring arm is lowered with out head unit, it MUST be held firmly. If it is released it will spring up, possibly causing serious injury. |
|  | ELECTRIC SHOCK: Disconnect all power and remove all fuses prior to assembly. |

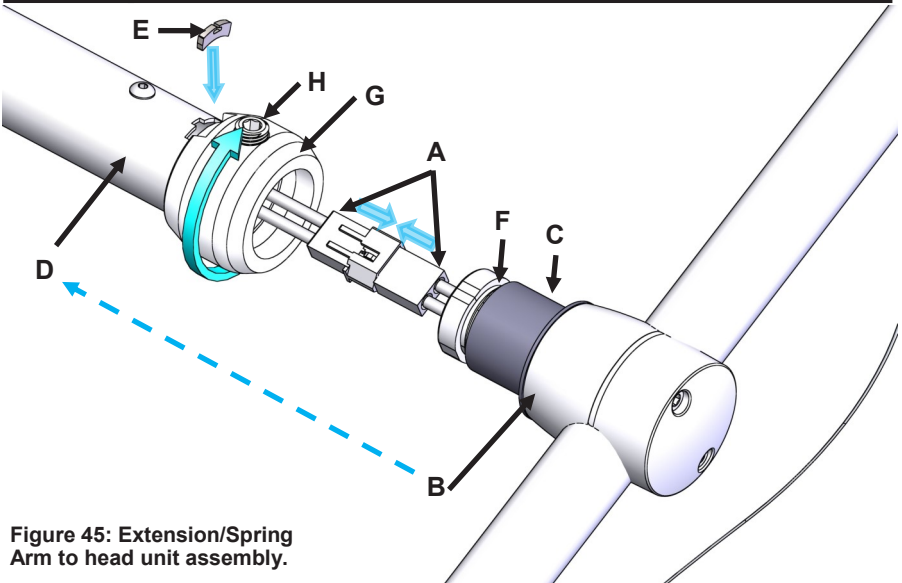





Figure 45: Extension/Spring Arm to head unit assembly.

1. Join the connectors (A). Then push the joined connectors partially into the yoke T-junction (B). Do not bend or twist. **CAUTION:** make sure the connectors (A) are fully engaged.
2. Make sure the plastic bearing (C) is sitting on the yoke T-junction (B).
3. Push the yoke T-junction (B) into the spring arm (D).
4. Push the locking key (E) completely into the slot, so that the key is engaging in the yoke T-junction groove (F).
5. Rotate the collar (G) 180 degrees until the hole in arm aligns with the set screw (H).
6. Tighten set screw (H) so that collar (G) cannot be rotated. If the collar rotates, reposition the set screw hole to the arm hole and try again. Once collar does not rotate, give set screw another 1/2 turn. **CAUTION:** Do not over tighten the set screw or the damage to the collar can occur.

| | |
|---|---|
|  | WARNING: It is critical that the locking key (E) is properly installed, the collar (G) is rotated 180° and the set screw is correctly positioned and tightened . Disregarding this instruction can present the risk of serious injury. |
|---|---|

9.0 Cleaning

9.1 Normal Cleaning

| | |
|---|--|
|  | ELECTRIC SHOCK: For all cleaning work, power off the equipment and secure it from being switched on again. Ensure that no cleaning fluid runs into the equipment. |
|  | Damage to equipment. Apart from mild detergents and isopropyl alcohol, no other cleaning agents or chemicals should be used on the product. |

Suggested cleaning technique is to use a soft cloth and mild detergent solution in water or isopropanol 70% solution. Do not let any solution run inside electrical assemblies. After cleaning, dry all surfaces promptly with a soft cloth or towel. For especially stubborn stains, rubbing or denatured alcohol can be used.

9.2 Extensive Cleaning

For more thorough cleaning of the light head, the top housing should be removed. This is done by first removing the pods to get access to the 3 screws holding the top and bottom housing together. See module replacement in the Instructions for Use. Remove the screws that has now become visible under the pod and lift the top housing off.

Use a soft cloth to wipe the corners and hidden surfaces when the parts are assembled. Be careful not to bend any components inside the light head. Damaging parts may affect the operation and light output.

| | |
|--|---|
|  | External surfaces are polycarbonate, or powder painted. Do not use cleaning agents, chemicals or solvents that can attack and damage polycarbonate material or stress corrosion cracking (SCC) will occur voiding the warranty. Under no circumstances should cleaning agents containing ester or a ketone solvents such as paint thinners, Methyl Ethyl Ketone-(MEK) MEK, acetonitrile, acetone, ethyl acetate be used. Always check the MSDS sheets. Use polycarbonate friendly cleaners. |
|--|---|

10.0 Equipment Anchorage Diagrams

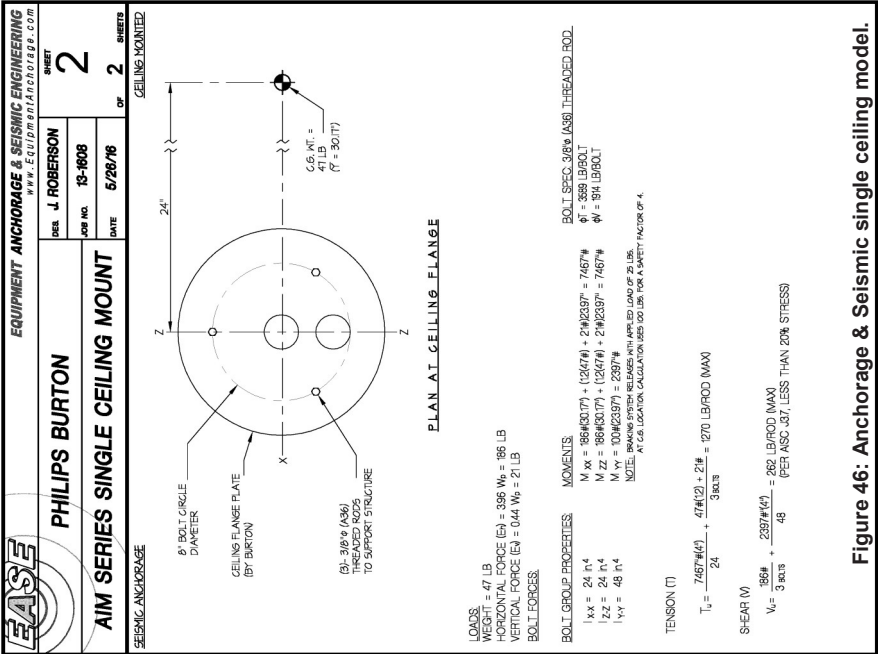
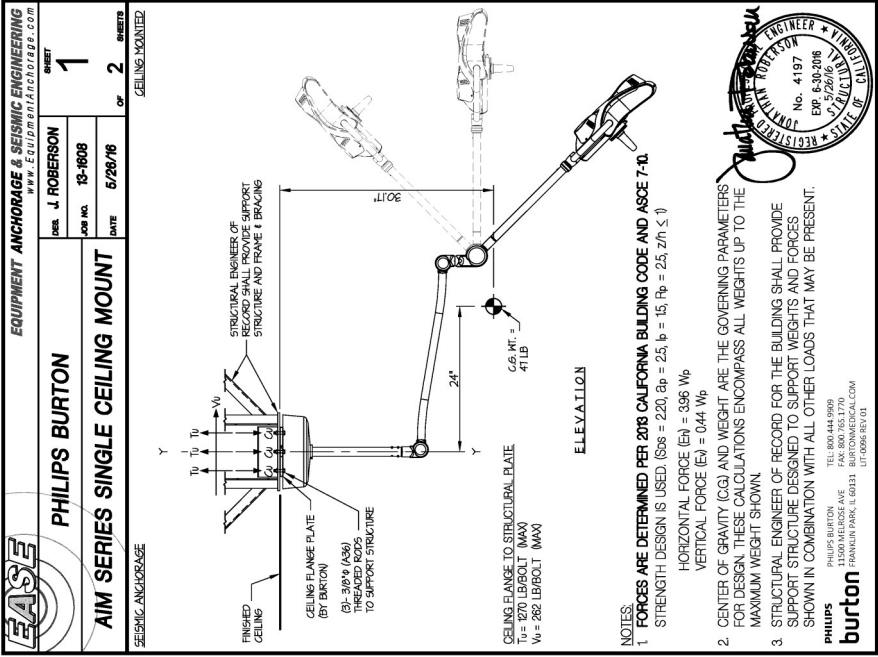

Figure 46: Anchorage & Seismic single ceiling model.

EASE EQUIPMENT ANCHORAGE & SEISMIC ENGINEERING
www.EquipmentAnchorage.com

DESIGNER: J. ROBERSON
JOB NO.: 13-1608
DATE: 5/28/16

PHILIPS BURTON
AIM SERIES DOUBLE CEILING MOUNT

SHEET 2 OF 2
SEISMIC ANCHORAGE

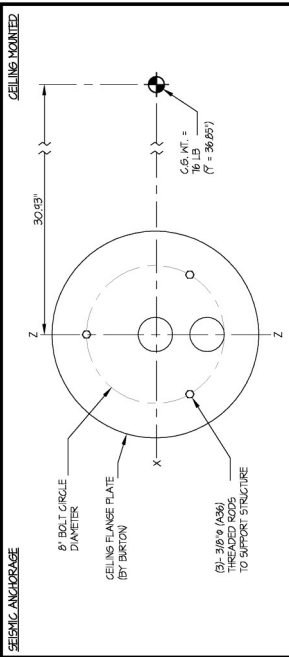

PLAN AT CEILING FLANGE

LOADS
WEIGHT = 76 LB
HORIZONTAL FORCE (E) = 356 W₆ = 301 LB
VERTICAL FORCE (E) = 0.44 W₆ = 33 LB
BOLT FORCES

BOLT GROUP PROPERTIES:
 $I_{xx} = 24 \text{ in}^4$
 $I_{yy} = 48 \text{ in}^4$
 $I_{zz} = 24 \text{ in}^4$
 $M_{xx} = 30146855\text{A} + (1975\text{A}) \cdot 3242032\text{E} = 14,633\text{#}$
 $M_{yy} = 30146855\text{A} + (1975\text{A}) \cdot 3242032\text{E} = 14,633\text{#}$
 $M_{zz} = 10048032\text{E} = 3283\text{#}$
 NOTE: BRACKING SYSTEM RELIABLE UP TO APPLIED LOAD OF 24 LBS.
 AT C.G. LOCATION CALCULATION USES 90 LBS FOR A SAFETY FACTOR OF 4.

BOLT SPEC. 3/8" (A36) THREADED ROD
 $\phi = 3/8\text{ IN}$ BOLT
 $\phi = 3/4\text{ IN}$ BOLT

TENSION (T)
 $T_1 = \frac{455334\text{A} + 764\text{I} + 334}{3 \cdot 8013} = 2530 \text{ LB/ROD (MAX)}$

CEILING MOUNTED

Figure 47: Anchorage & Seismic double ceiling model.

EASE EQUIPMENT ANCHORAGE & SEISMIC ENGINEERING
www.EquipmentAnchorage.com

DESIGNER: J. ROBERSON
JOB NO.: 13-1608
DATE: 5/28/16

PHILIPS BURTON
AIM SERIES DOUBLE CEILING MOUNT

SHEET 1 OF 2
SEISMIC ANCHORAGE

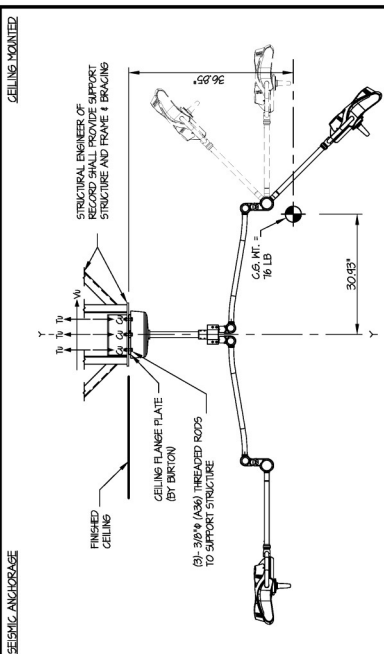

CEILING FLANGE TO STRUCTURAL PLATE
 $T_1 = 2530 \text{ LB/BOLT (MAX)}$
 $V_1 = 598 \text{ LB/BOLT (MAX)}$

NOTES:
 1. FORCES ARE DETERMINED PER 2018 CALIFORNIA BUILDING CODE AND ASCE 7-10. STRENGTH DESIGN IS USED. (SOS = 2.20, ap = 25, b = 15, Rp = 25, z/n ≤ 1)
 2. CENTER OF GRAVITY (CG) AND WEIGHT ARE THE GOVERNING PARAMETERS FOR DESIGN. THESE CALCULATIONS ENCOMPASS ALL WEIGHTS UP TO THE MAXIMUM WEIGHT SHOWN.
 3. STRUCTURAL ENGINEER OF RECORD FOR THE BUILDING SHALL PROVIDE SUPPORT STRUCTURE DESIGNED TO SUPPORT WEIGHTS AND FORCES SHOWN IN COMBINATION WITH ALL OTHER LOADS THAT MAY BE PRESENT.

HORIZONTAL FORCE (E) = 356 W₆
 VERTICAL FORCE (E) = 0.44 W₆

PHILIPS BURTON
 800.444.5909
 PHILIPS BURTON ENGINEERING
 BURTONMEDICAL.COM
 FRANKLIN PARK, IL 60131
 (708) 697-1610

burton

Professional Engineer Seal: No. 4197, Exp. 6/30/2016, State of Illinois, Mechanical Engineering.



PHILIPS BURTON

DES. **J. ROBERSON**

SHEET

1

AIM SERIES WALL MOUNT

JOB NO. **13-1808**

DATE **5/19/16**

OF **2** SHEETS

SEISMIC ANCHORAGE

WALL MOUNTED

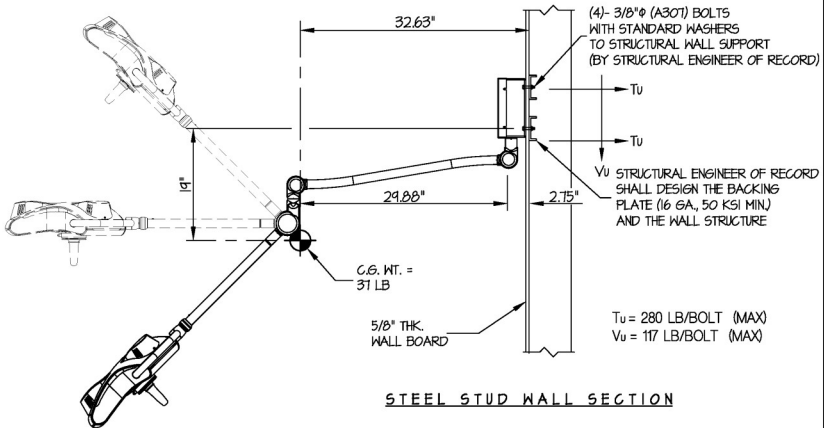

NOTES:

- FORCES ARE DETERMINED PER 2013 CALIFORNIA BUILDING CODE AND ASCE 7-10.**
STRENGTH DESIGN IS USED. ($S_{Ds} = 2.20$, $a_p = 2.5$, $l_p = 15$, $R_p = 2.5$, $z/h \leq 1$)
HORIZONTAL FORCE (E_h) = $3.96 W_p$
VERTICAL FORCE (E_v) = $0.44 W_p$
- CENTER OF GRAVITY (C.G.) AND WEIGHT ARE THE GOVERNING PARAMETERS FOR DESIGN. THESE CALCULATIONS ENCOMPASS ALL WEIGHTS UP TO THE MAXIMUM WEIGHT SHOWN.
- STRUCTURAL ENGINEER OF RECORD FOR THE BUILDING SHALL PROVIDE SUPPORT STRUCTURE DESIGNED TO SUPPORT WEIGHTS AND FORCES SHOWN IN COMBINATION WITH ALL OTHER LOADS THAT MAY BE PRESENT.

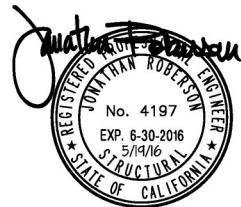

PHILIPS burton
PHILIPS BURTON
11500 MELROSE AVE
FRANKLIN PARK, IL 60131
TEL: 800.444.9909
FAX: 800.765.1770
BURTONMEDICAL.COM
UT-0098 REV 01

Figure 48: Anchorage & Seismic wall model.

PHILIPS BURTON

AIM SERIES WALL MOUNT

DES. **J. ROBERSON**

JOB NO. **13-1608**

DATE **5/19/16**

SHEET

2

OF **2** SHEETS

SEISMIC ANCHORAGE

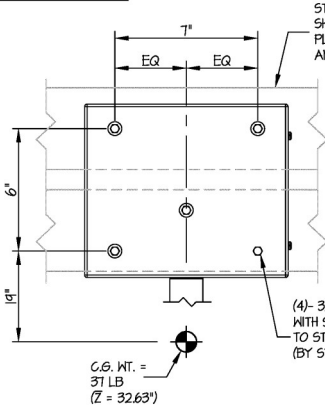

STRUCTURAL ENGINEER OF RECORD SHALL DESIGN THE BACKING PLATE (1/8 GA, 50 KSI MIN) AND THE WALL STRUCTURE

2 x STUDS OR 4 x BLKG (DOUGLAS-FIR LARCH NUMBER 2 MIN) (DESIGNED BY STRUCTURAL ENGINEER OF RECORD)

(4)- 3/8"φ (A307) BOLTS WITH STANDARD WASHERS TO STRUCTURAL WALL SUPPORT (BY STRUCTURAL ENGINEER OF RECORD)

C.G. WT. = 37 LB
($\bar{Z} = 32.63"$)

ELEVATION AT WALL PLATE

(4)- 3/8"φ x 3" LAG SCREWS AT EACH WOOD STUD OR BLKG. (PRE-DRILL HOLES TO 10% SHANK DIAMETER)

5/8" THK. WALLBOARD (ONE LAYER MAX)

WOOD STUD WALL SECTION

LOADS: PER 2013 CALIFORNIA BUILDING CODE AND ASCE 7-10.
STRENGTH DESIGN IS USED ($S_{ds} = 2.20, a_p = 2.5, b = 15, F_p = 2.5, z/f_1 \leq 1$)

WEIGHT = 37 LB
HORIZONTAL FORCE (E_h) = $3.96W_p = 147$ LB
VERTICAL FORCE (E_v) = $0.44W_p = 16$ LB

BOLT FORCES:

TENSION (T)

$$T_{U \text{ VERTICAL}} = \frac{(12(37\#) + 16\#)(32.63")}{2 \text{ BOLTS } (6")} = 164 \text{ LB/BOLT}$$

$$T_{U \text{ PARALLEL}} = 0 \text{ LB (FREELY ROTATES } 180')$$

$$T_{U \text{ PERP.}} = \frac{147\# (19")}{4 \text{ BOLTS } (6")} = 116 \text{ LB/BOLT}$$

$$T_{U \text{ MAX}} = 164\# + 153\# = 280 \text{ LB/BOLT (MAX)}$$

SHEAR (V)

$$V_{U \text{ AGAINST WALL}} = \sqrt{\left(\frac{(12(37\#) + 16\#)(29.88")}{2 \text{ BOLTS } (7")}\right)^2 + \left(\frac{147\# (19")}{4 \text{ BOLTS } (6")}\right)^2} + \left(\frac{12(37\#) + 16\#}{4 \text{ BOLTS}}\right)^2 = 246 \text{ LB/BOLT (MAX) OK}$$

$$V_{U \text{ MAX @ } T_{U \text{ MAX}}} = \sqrt{\left(\frac{12(37\#) + 16\#}{4 \text{ BOLTS}}\right)^2 + \left(\frac{147\# (19")}{4 \text{ BOLTS } (6")}\right)^2} = 117 \text{ LB/BOLT (MAX)}$$

BOLT SPEC: 3/8"φ (A307) BOLTS

$\phi T = 3355$ LB/BOLT

$\phi V = 1723$ LB/BOLT

3/8"φ LAG SCREWS

$\phi T = 939$ LB/SCREW

$\phi V = 339$ LB/SCREW

UNITY CHECK:

$$\left(\frac{T_u}{\phi T}\right) + \left(\frac{V_u}{\phi V}\right) \leq 10$$

$$\left(\frac{280}{939}\right) + \left(\frac{117}{339}\right) = 0.64 \leq 10 \therefore \text{OK}$$

Figure 49: Anchorage & Seismic wall model.

11.0 AIM HI LED Single/Double/Wall Mount Wiring Diagram

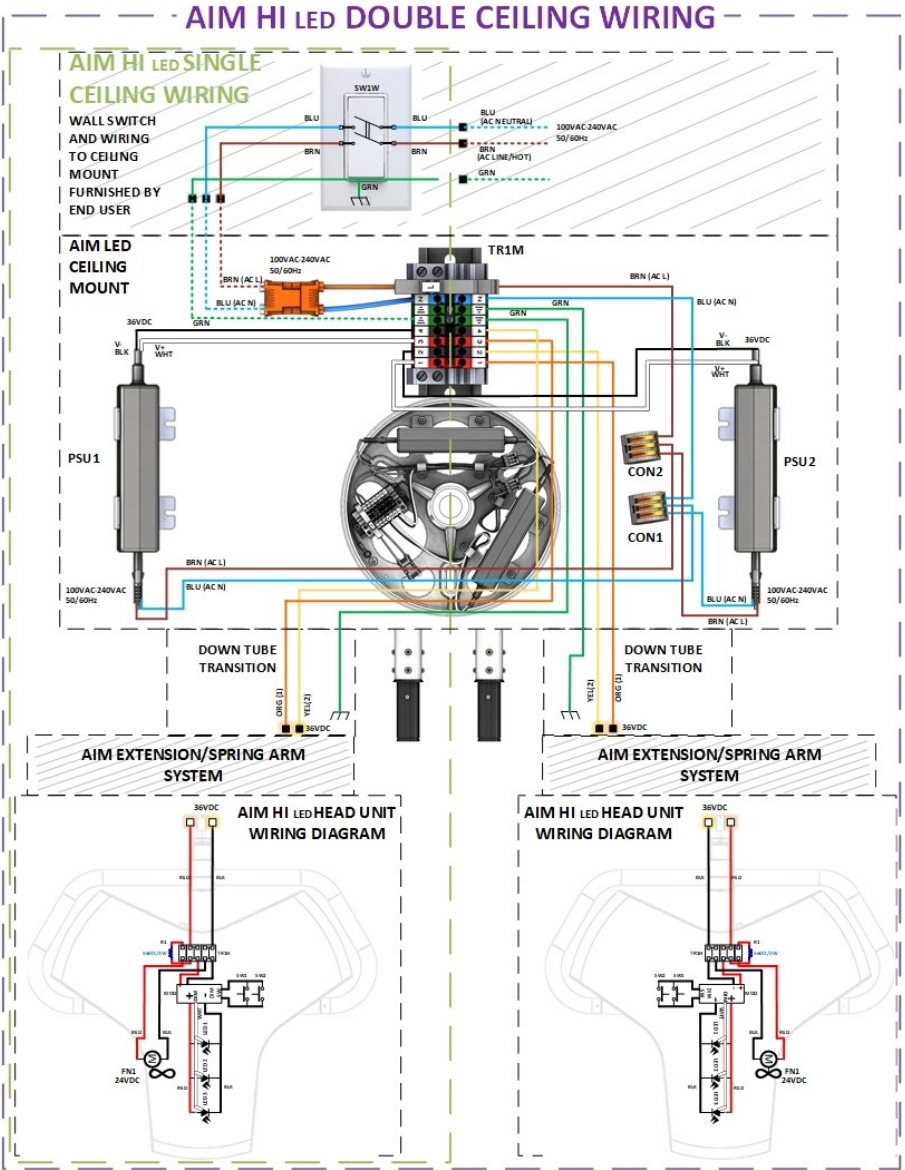

Figure 50: AIM HI LED Single/Double/Wall mount wiring diagram.

12.0 Warranty Information

For complete, detailed information on your specific product's warranty coverage, please visit:
<http://www.burtonmedical.com/wp-content/themes/burtonmedical/literature/warranty.pdf>

NOTES:

This product was designed and manufactured in the U.S.A. by:

Burton Medical LLC
2300 W Windsor Ct., STE C
Addison, IL 60101
U.S.A.

Tel.: (800) 444-9909

Fax: (800) 765-1770

Web: www.burtonmedical.com

EU Authorized Representative:

Wellkang Ltd
29 Harley St.
Q1G 9QR
London, U.K.

Tel: +44(20)32876300 ext 1

Fax: +44(20)76811874